

Experimental Investigation of a Small Capacity Steam-Ejector Refrigerator

Satha Aphornratana

Department of Mechanical Engineering
Sirindhorn International Institute of Technology, Thammasat University
Rangsit Campus, Klong Luang, Patumthani 12121
THAILAND

ABSTRACT

This paper describes an experimental study of a steam-ejector refrigerator. A 1 kW cooling capacity refrigerator has been tested with boiler temperatures from 120 °C to 140 °C and evaporator temperatures from 5 °C to 10 °C. The cooling capacity and COP were found to be very sensitive to all operating temperatures. The choking of the working fluid in the mixing chamber of the ejector was found to be very important to the system performance.

NOMENCLATURES

COP	Coefficient of Performance
COP_{elec}	Coefficient of Performance based on electric power input
COP_{mass}	Coefficient of Performance based on mass flow rate
COP_{theo}	Coefficient of Performance based on the computer model
I	electric current (Amp.)
h	specific enthalpy (kJ.kg ⁻¹)
m	mass flow (kg.sec ⁻¹ , kg.min ⁻¹)

NXP	Nozzle Exit Position (see Fig. 3)
Q	heat energy rate (kW)
$Volt$	Voltage (V)

SUBSCRIPTS

<i>boiler</i>	boiler
<i>evap</i>	evaporator
<i>con</i>	condenser
<i>f</i>	saturated liquid
<i>v</i>	saturated vapor

1. INTRODUCTION

An ejector refrigerator is similar to an absorption refrigerator, since both can be powered mainly by low grade heat energy, with a small work input commonly required to circulate the fluids. Therefore, they can convert waste heat to useful refrigeration and may be cheaper to operate than a conventional vapor compression cycle whose energy input is entirely in the form of mechanical work.

Experimental study provided in the literature showed that an ejector refrigerator may provide a lower Coefficient of Performance (COP) than an absorption system when they are operated under the same conditions [1]. However, system configuration of the ejector system is more simple. It is also easy to operate since there is no chemical process involved (such as absorption and distillation processes in an absorption refrigeration cycle) and only a single component working fluid is used (refrigerant only). Thus, the ejector refrigerator may be attractive to be developed for a low cost heat powered

refrigerator.

Fig. 1 shows a schematic diagram of an ejector refrigeration cycle. High pressure and high temperature refrigerant vapor is evolved in the boiler to produce the primary (motive) fluid. This enters the primary nozzle of the ejector, where it expands to produce a supersonic flow that creates a low pressure region within the mixing chamber. This region of low pressure draws a low pressure vapor from the evaporator (a secondary flow). The primary and secondary fluids are mixed in the mixing chamber of the ejector. At the mixing chamber's throat, a transverse shock is induced to create a major compression effect. Then the mixed stream is discharged via the diffuser to the condenser, where the vapor is condensed. The liquid refrigerant accumulated in the condenser is returned to the boiler via a pump whilst the remainder is expanded through the throttling valve to the evaporator, thus completing the cycle. As the work input required to circulate the fluid is typically less than 1 % of the heat supplied to the boiler, the Coefficient of Performance may be given as:

$$COP = \frac{Q_{evap}}{Q_{boiler}} \quad (1)$$

Small capacity ejector refrigerators using R11, R12, and R113 as working fluids have been reported [2-4]. However, the author was not aware of any small capacity systems operated with low pressure steam. Normally, steam ejectors are operated using steam supplied from industrial boilers with saturation pressure in the range of 5 bar to 20 bar [5]. Theoretical study of a steam ejector refrigerator was already provided in the literature [6].

This paper provides the results of an experimental study of a 2 kW cooling capacity steam ejector refrigerator. The experimental refrigerator was tested with the boiler temperatures ranging from 120 °C to 140 °C and with evaporator temperatures ranging from 5 °C to 10 °C. The system was also tested using two different primary nozzles.

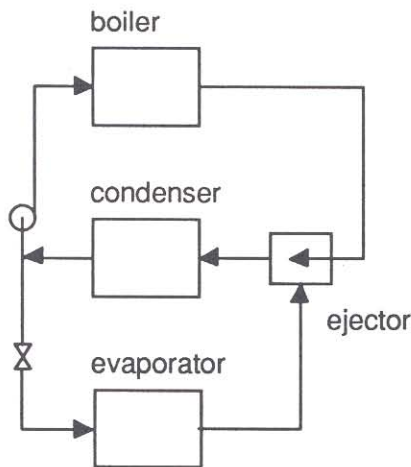

Fig. 1. An ejector refrigeration cycle.

2. EXPERIMENTAL REFRIGERATOR

An experiment refrigerator with a cooling capacity of 2 kW was constructed. Fig. 2 shows a schematic diagram of the system. All vessels were constructed from stainless steel. The boiler design was based on the thermo-syphon principle. The maximum heating capacity of the boiler was 7 kW, provided by two 3.5 kW electric heaters. The evaporator design was based on a spray and falling film column. A single 3.25 kW heater was used to simulate the evaporator heat load. All the electric heaters were controlled using variable transformers. A shell and coil condenser was used, cooled by water taken from the laboratory's cooling tower.

Two circulation pumps were employed in the system; a pneumatic diaphragm pump were used to pump the liquid water collected in the condenser to the boiler and evaporator, and a magnetically coupled centrifugal pump was used to circulate water through the evaporator.

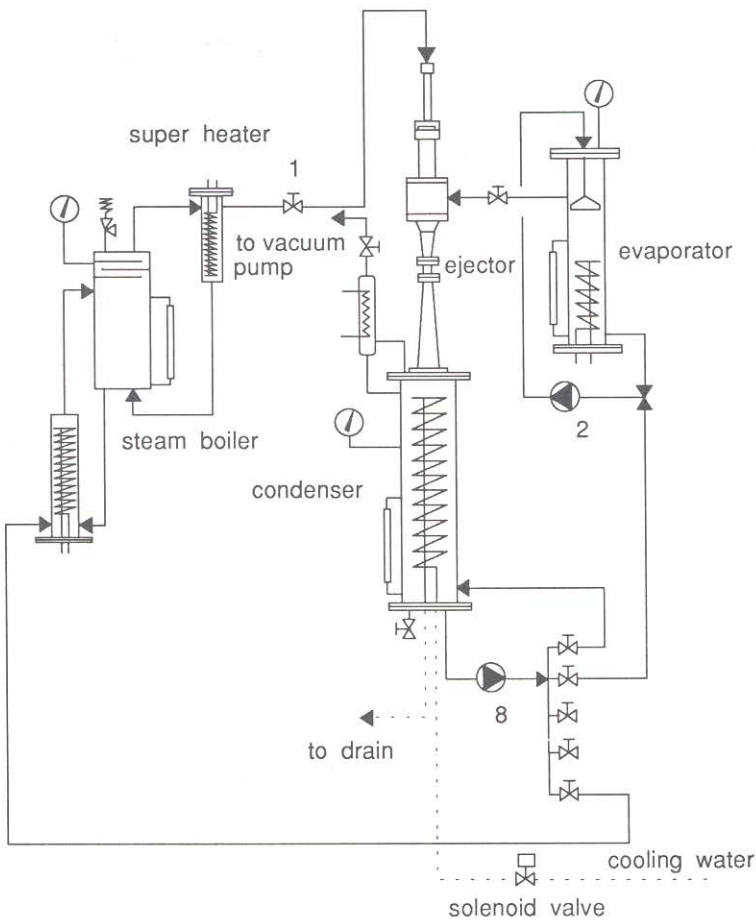

Fig. 2. Schematic diagram of the experimental steam ejector refrigerator.

Fig. 3 shows a sectional drawing of the test ejector. It was designed based on methods provided in the literature [5-7]. Two different primary nozzles were used to test the influence of the geometry on the ejector performance. The nozzle was mounted on a threaded shaft which allowed the distance between the nozzle exit and the mixing chamber inlet to be adjusted in order to determine the influence of the nozzle position on the performance of the ejector. The Nozzle Exit Position (NXP) was defined as the distance between the nozzle exit and the mixing chamber inlet planes as shown in Fig. 2. The NXP has a positive value when the nozzle is placed inside the mixing chamber, and is negative when outside the mixing chamber. In this experiment, NXP was fixed at 26 mm.

The experimental refrigerator was designed to be computer controlled. Maximum electrical power input to the boiler and evaporator heaters were set using variable transformers, however, fine adjusting of these inputs was achieved by on-off switching via electrical relays, controlled automatically through a computer to maintain selected set-point temperatures and record automatically by the computer. Condenser temperature was controlled by varying cooling water flow rates using proprietary solenoid control valves. Sight glasses were provided in each vessel to allow liquid levels to be monitored. Liquid levels were controlled through infra-red switches positioned on the sight glasses. In each case, a small plastic float interrupted an infra-red beam, as the liquid level rose above or fell below the set point level, causing an electrical signal to trigger the opening or closing of solenoid valve in the liquid feed pump circuit.

The boiler, condenser, and evaporator were charged with deionized water. The performance of the experimental refrigerator was obtained by measuring the time averaged electric power input to the evaporator and generator heaters over a steady state running time of 30 to 60 min. Results over a range of operating temperatures and pressure at the generator condenser, and evaporator were recorded.

3. EXPERIMENTAL METHOD

Even though all the system was designed to be fully automatically controlled, the example of the operating techniques are provided by assuming that the system is manually operated and controlled.

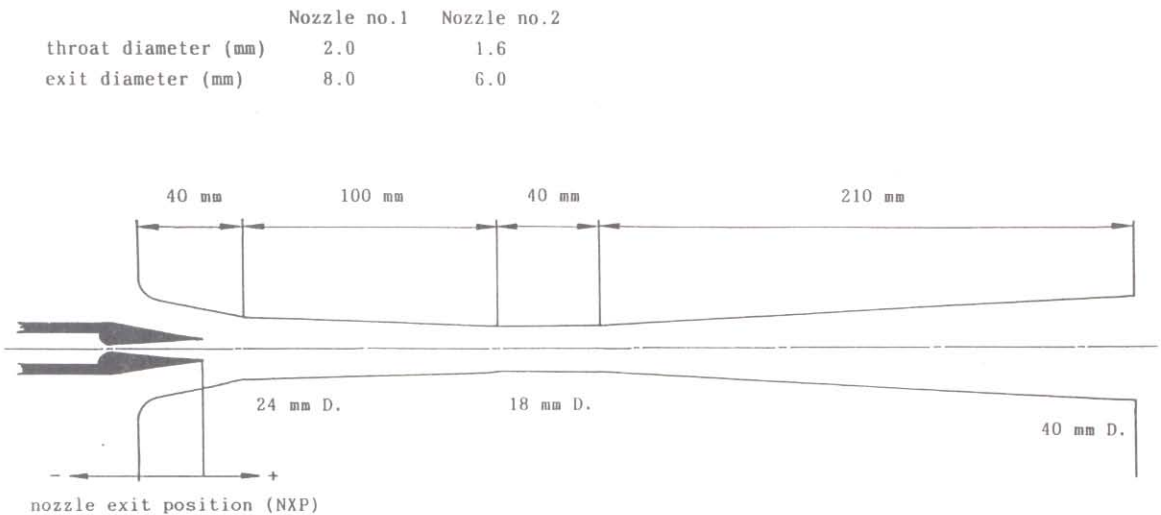

Fig. 3. Schematic diagram of the experimental steam ejector refrigerator.

Before operating the system, all non-condensable gases must be removed from the system. A vacuum pump is used to evacuate the system for 5 to 10 min. When all the gases are removed, the pressure measured by a digital manometer installed at the condenser shows a minimum value.

After all non-condensable gases are evacuated from the system, (referring to Fig. 2) the boiler is isolated from the rest of the system by closing valve (1). Then, the boiler heaters are switched on. At first, the heaters' power is kept below 2000 W in order to avoid violent kettling noises which are produced from the cavitation of vapor bubbles leading to possible damage of the immersion heaters. After 10 min, the heaters' power can be increased to their maximum value without any kettling noise. When a required temperature is reached, valve (1) is opened to allow the high pressure steam to enter the primary nozzle of the ejector. The electric power input to the boiler heaters must be adjusted in order to maintain a constant temperature. Without any cooling water flowing through the condenser coils, the condenser temperature increases rapidly. The cooling water is turned on in order to maintain a constant pressure in the condenser. Then, the evaporator recirculation pump (2) is switched on. As the evaporator temperature continues to drop, the heater is turned on. The heater's power input is gently adjusted in order to maintain a constant temperature in the evaporator. Since the water level in the boiler and evaporator are monitored by infra-red switches, the condensate collected at the bottom of the condenser is continually pumped back (through pump 8) to the boiler and evaporator.

In order to avoid wet steam at the nozzle inlet, the superheater may be switched on. Electric power input to the heater is adjusted in order to superheat saturated steam from the boiler before entering the primary nozzle. Superheat by a few degrees helps ensure that the steam remains dry otherwise there is no other advantage [5].

4. EXPERIMENTAL RESULTS

4.1 Effect of Operating Temperatures

The experiment was carried out over ranges of boiler, condenser, and evaporator temperatures using primary nozzle no. 1. During the experiment, electric power input to the boiler and the evaporator were measured. Refrigerator COP based on electric power input was calculated using the following equation:

$$COP_{elec} = \frac{(Volt \times I)_{evap}}{(Volt \times I)_{boiler}} \quad (2)$$

COP_{elec} is a measure of overall performance and includes all the unwanted heat losses and gains to the system.

Figs. 4 and 5 show the effect of operating temperatures on system performance (data are also listed in Table 1). The results showed that:

- The heat input to the boiler and the critical mass flow rate of the primary steam were functions of the steam pressure and temperature only and independent of the evaporator and condenser conditions, because the nozzle always operated in a choked condition throughout.
- Coefficient of Performance remained constant because cooling capacity and boiler heat input were maintained constant when the condenser pressure was raised. This was thought to be caused by the choking of the mixed fluid in the mixing chamber which will be discussed later. At a certain

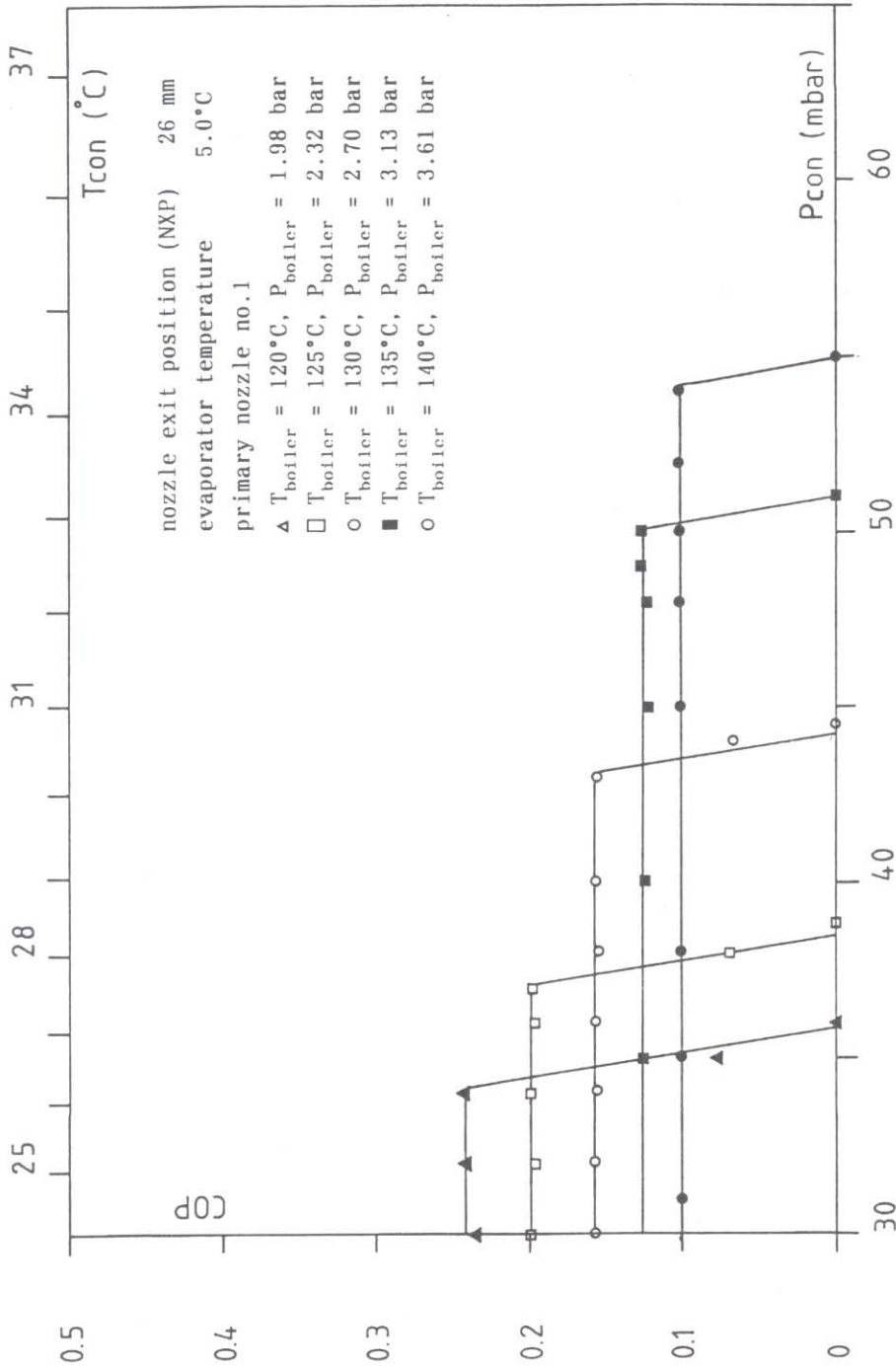

Fig. 4. Variation of experimental performance (COP_{elec}) with boiler temperatures and condenser pressures for the evaporator temperature of 5 °C.

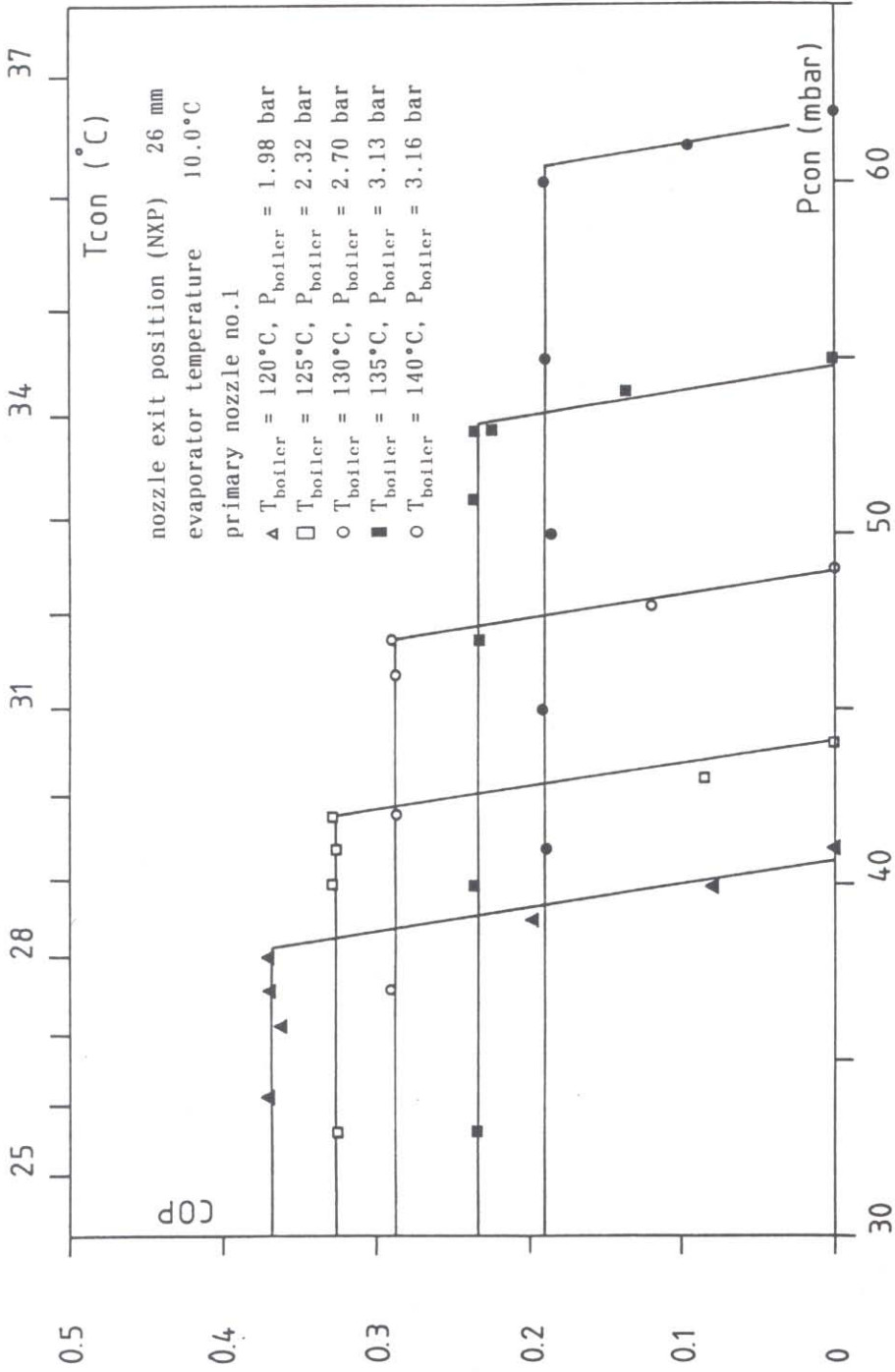

Fig. 5. Variation of experimental performance (COP_{elec}) with boiler temperatures and condenser pressures for the evaporator temperature of 10 °C.

condenser pressure the COP dropped sharply to zero. The condenser pressure at which the COP started dropping is known as the 'critical condenser pressure' [4].

- For a given evaporator temperature, increasing the boiler pressure and temperature resulted in a decrease in COP (cooling capacity decreased, boiler input increased). However, it was found that the cycle could be operated at a higher critical condenser pressure.
- When the boiler pressure and temperature were held constant, it was found that increasing the evaporator temperature caused the COP to rise (cooling capacity increased, boiler heat input remained constant). Under these conditions it was found that the cycle could be operated at a higher critical condenser pressure.

For given boiler temperature and pressure (as the primary nozzle was operated in a choked condition, the primary fluid mass flow was constant for fixed boiler temperature and pressure and independent of both evaporator and condenser conditions), when the cycle was operated with the condenser pressure below its critical value the COP and cooling capacity were found to be constant because the ejector entrained the same amount of the secondary fluid. This phenomenon was thought to be caused by the flow choking within the mixing chamber (up stream of the diffuser) [4,8].

When the ejector was operated at its critical condenser pressure, a transverse shock, which creates a compression effect is believed to appear in the constant area mixing section. This was noticeable during experimentation that there was a sudden rise of the temperature at the mixing chamber throat surface when operating the ejector at a critical condenser pressure. This was thought to have resulted from the sudden compression effect of a shock wave. When the condenser pressure is increased to a value higher than the critical value, the transverse shock tends to move back (opposite to the flow direction). As this occurs, the secondary flow begins to fall off rapidly. If the condenser pressure is further increased, the ejector may lose its function completely and some of the primary fluid may flow back into the evaporator. This was identified experimentally by a sudden increase in evaporator temperature, probably caused by the hot primary stream flowing into it.

The mixing process in the mixing chamber is complicated, and it is still not well understood exactly how the primary and secondary streams are mixed. Munday and Bagster [8] explained that after expanding through the primary nozzle, the primary fluid initially fans out without mixing with the secondary fluid and results in a converging duct for the secondary flow. The secondary fluid is gradually entrained through this 'duct' and accelerated to sonic velocity at some cross section. This cross section area was defined by Munday and Bagster as the 'effective area'. Munday and Bagster suggested that mixing of the two streams begins after the secondary flow chokes. However, even though this theory seems to explain what happens in the mixing chamber, it has not been proved experimentally (there is no experimental evidence that the mixing of two streams starts after the secondary flow choking).

Schlieren photographs provided by Liepmann and Roshko [9] gave qualitative information on the effect of changing the primary fluid pressure. These photographs showed that increasing the pressure ratio across the nozzle (by increasing the boiler pressure) causes the penetration distance of the oblique expansion waves to increase as shown in Fig. 6. The primary nozzle was normally operated with an underexpanded condition (confirmed by calculation), therefore, a network of oblique expansion waves is formed at the nozzle exit. More information on the oblique expansion waves is provided in the literature [9-10]. It was thought that these oblique expansion waves reduce the mixing rate between the primary and secondary streams. Increasing the boiler pressure will increase the length of the oblique expansion waves, and therefore reduce the mixing rate and allow less secondary flow to be entrained, and vice versa. If the exit area of the nozzle can be varied, the nozzle can be adjusted to be operated at its design pressure or slightly underexpanded when the boiler pressure is increased. The mixing rate should be improved and more secondary flow can be entrained, therefore increasing

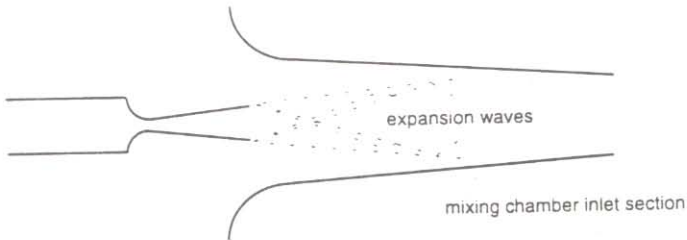

Fig. 6. Oblique expansion waves at the primary nozzle exit.

cooling capacity and COP.

4.2 Effect of the Area Ratio

An ejector area ratio may be defined as the ratio of the mixing chamber throat area to the primary nozzle throat area. In the literature [1], theoretical results showed that ejector performance was dependent on the area ratio. In this experiment, two primary nozzles with difference geometry were tested; nozzle no.1 with throat diameter of 2 mm and exit diameter of 8 mm; nozzle no.2 with throat diameter of 1.6 mm and exit diameter of 6 mm. These nozzles represented ejector area ratios of 81 and 127 respectively. Both nozzles were tested with the Nozzle Exit Position (NXP) at 26 mm. Fig. 7 derived from experimental data shows the effect of these two nozzle geometry on system performance over a range of operating conditions (data is also listed in Table 1). It was found that, at the same boiler and evaporator temperatures, when nozzle no.2 was fitted the system provided a higher COP (higher cooling capacity, lower boiler heat input) but at a lower critical condenser pressure than when nozzle no.1 was fitted.

The ejector performance and operating conditions can be changed by using different primary nozzle geometry. However, it can not be said which nozzle is better than the other. For a given evaporator temperature, an ejector with small primary nozzle throat (large area ratio) is suitable to be operated with a high pressure primary steam or a low condenser pressure, and vice versa. On the other hand, it may be said that, at the same condenser and evaporator conditions, an ejector which is designed to operate with high boiler pressure requires larger area ratio and provides a higher COP than the one designed for low pressure boiler (smaller area ratio).

5. EXPERIMENTAL ERRORS

It was already mentioned that, the COP_{elec} is a measure of overall performance and includes all

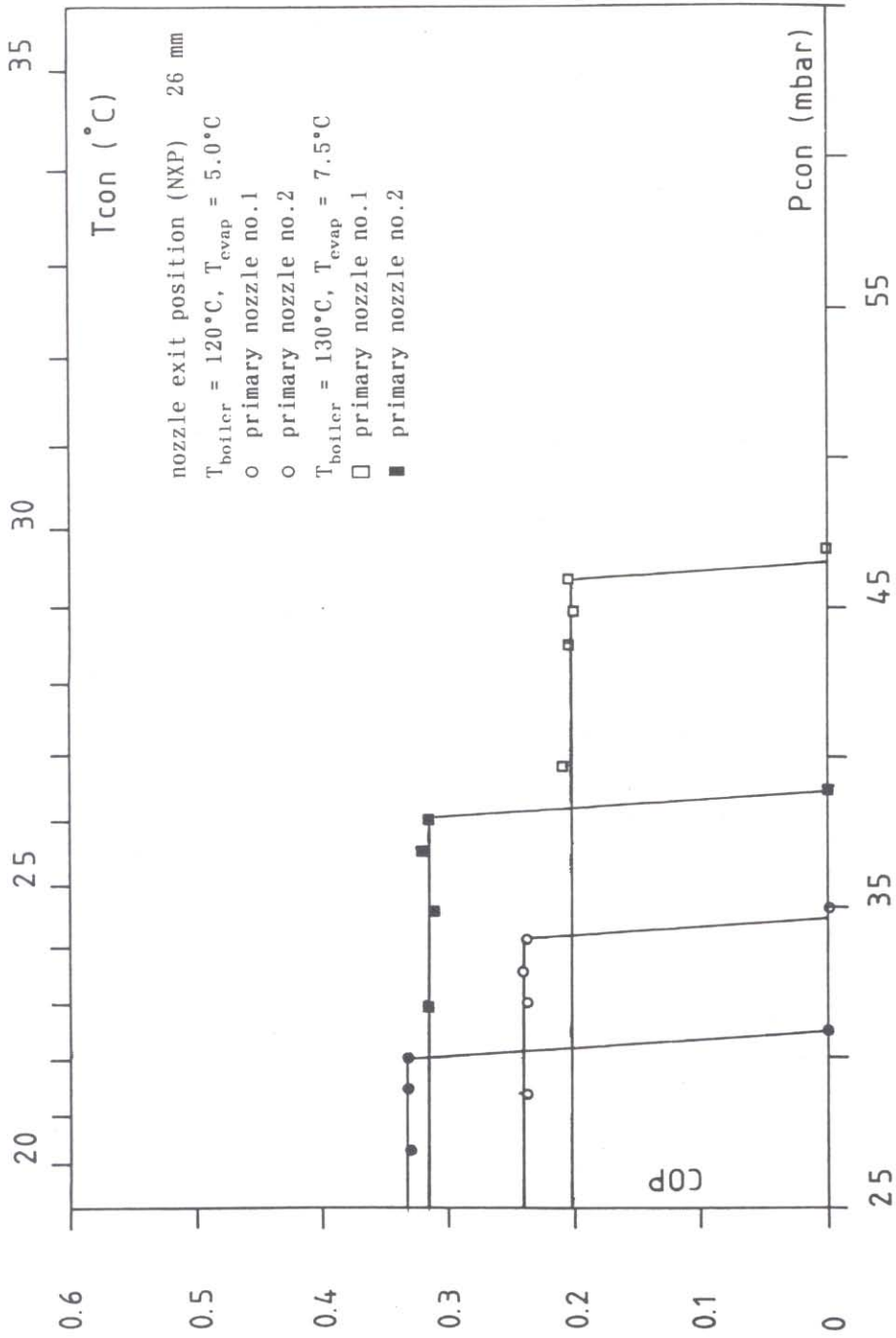

Fig. 7. Variations of experimental performance (COP_{elec}) with condenser pressure using two different primary nozzles for an evaporator temperature of 5°C at the generator temperature of 120°C .

Table 1. Performance of the steam ejector refrigerator at critical condenser pressure operation.

evap	temp (°C) boiler	P (mbar)		(electric power)		(mass flow rate)		(theoretical)
		con	con	Q _{evap} (W)	COP	Q _{evap} (W)	COP	COP
<i>ejector with nozzle No.1, area ratio of 81</i>								
5.0	120	26.5	34	631	0.2385	752	0.3747	0.5081
	125	27.8	37	590	0.1969	707	0.3189	0.4660
	130	30.8	44	528	0.1567	633	0.2557	0.3645
	135	33.4	51	479	0.1265	578	0.2067	0.2841
	140	34.4	54	434	0.1021	531	0.1649	0.2765
7.5	120	27.3	36	811	0.3065	932	0.4644	0.5966
	125	29.5	41	750	0.2503	871	0.3929	0.5052
	130	31.5	46	698	0.2072	826	0.3336	0.4356
	135	33.4	51	656	0.1733	810	0.2897	0.3786
10.0	120	28.3	38	977	0.3693	1091	0.5436	0.6849
	125	29.8	42	981	0.3274	1105	0.4984	0.6183
	130	31.9	47	971	0.2882	1087	0.4390	0.5299
	135	34.0	53	896	0.2367	1009	0.3609	0.4544
	140	36.3	60	800	0.1882	923	0.2867	0.3822
<i>ejector with nozzle No.2, area ratio of 127</i>								
5.0	120	24.1	30	743	0.3329	817	0.5662	0.6332
	125	25.9	33	750	0.2931	842	0.5021	0.5542
	130	27.3	36	694	0.2504	783	0.4307	0.5031
	135	28.9	40	650	0.2039	722	0.3455	0.4486
7.5	120	24.6	31	893	0.4001	1056	0.7318	0.7624
	125	26.5	34	900	0.3517	965	0.5754	0.6613
	130	28.3	38	880	0.3175	952	0.5239	0.5801
	135	29.1	40	835	0.2619	902	0.4316	0.5560
10.0	120	25.9	33	1100	0.4928	1137	0.7879	0.8515
	125	27.8	37	1100	0.4299	1127	0.6720	0.7386
	130	28.5	39	1107	0.3994	1200	0.6604	0.7141
135	31.2	45	1090	0.2811	1134	0.5426	0.5805	

electrical power data based on electrical input
mass flow rate data based on mass flow rate of the working fluid
theoretical data based on computer model [6]

the unwanted heat losses and gains to the system. Therefore, in order to eliminate the experimental error produced by these unwanted heat transfers, water evaporation rates in the boiler and the evaporator were measured with the cycle operating in steady state. Evaporation rates were obtained by measuring changes in liquid volume in the boiler and evaporator over a finite time interval. Coefficient of Performance based on evaporation rates was then calculated from:

$$COP_{mass} = \frac{m_{evap} (h_{v, evap} - h_{f, con})}{m_{boiler} (h_{v, boiler} - h_{f, con})} \tag{3}$$

Table 1 shows comparison of the experimental data based on electrical power and mass flow rate. By comparing the evaporation rates with the electric power input, the average boiler heat loss was estimated to be 25% of the electrical power input. Similarly, the average evaporator heat gain was found to be approximately 12%. The unexpectedly high heat gain at the evaporator was thought to be a result of the heat conduct from the ejector body as the ejector body was found to be relatively hot during operation. After these unwanted heat transfers were eliminated from the performance calculations, COP_{elec} was found to be approximately 65% of COP_{mass} . Table 1 also shows theoretical data based on computer model provided by Aphornratana [6]. The Coefficient of Performance (COP_{mass}) was found to be within 70 % to 90% of the COP_{theo} .

6. CONCLUSIONS

Experimental studies of a small scale steam ejector refrigerator were described. The system was tested with boiler temperatures between 120 °C and 140 °C, and evaporator temperatures between 5 °C and 10 °C. Coefficient of Performance based on electric power input to the boiler and evaporator (COP_{elec}) of 0.1 to 0.5 was found. When all the unwanted heat transfers were eliminated from the calculations, Coefficient of Performance based on working fluids mass flows and thermodynamic properties (COP_{mass}) of 0.15 to 0.8 was found. Both COP and cooling capacity were found to be very sensitive to all operating temperatures. Apart from the operating temperatures, the experiments also showed that system performance was strongly dependent on the primary nozzle throat diameter. Experimental data were compared with theoretical predictions. Coefficient of Performance (COP_{mass}) was found to be approximately 80% of theoretical predictions. If a better design of ejector (e.g., large suction pipe, different shapes, and geometry) were used, performance as good as the computer predictions might be obtained.

The cooling capacity was shown to be limited by the condenser pressure, which is governed by the temperature of the cooling water. The cooling capacity could only be increased by reducing the boiler temperature as the condenser pressure falls or by allowing the evaporator temperature to be raised.

The experiment with two different primary nozzles showed that, when nozzle no.2 (smaller throat area) was fitted, the system provided a higher COP, higher cooling capacity, and lower boiler heat input than when nozzle no.1 (larger throat area) was fitted. However, the system with nozzle no.2 could only be operated at a lower critical condenser pressure.

More flexible operation may be obtained, if the cross sectional areas of the primary nozzle throat and outlet and the mixing chamber throat were adjustable. The primary nozzle could be designed similar to a metering valve. The flow rate of the high pressure steam could be adjusted by moving a tapered needle within a throat. The annular duct formed between the needle and the body would act as a divergent nozzle. The mixing chamber may be made from flexible material, so that the shape can be varied by mean of an external force.

A small scale steam ejector refrigerator was proved to be practical. It was shown that it can be operated with low grade heat energy with temperatures ranking from 120 °C to 140 °C. The system was simple to operate, and reliable (two mechanical pumps were the only moving parts). However, the system flexibility at off design operation was shown to be limited by the performance characteristics of the ejector.

7. REFERENCES

1. Aphornratana, S. 1994. Theoretical and Experimental Investigation of a Combined Ejector-Absorption Refrigerator. Ph.D. Thesis, The University of Sheffield, U.K..
2. Hamner, R. M. 1978. An Investigation of an Ejector-Compression Refrigeration Cycle and its Applications to Heating, Cooling, and Energy Conservation. Ph.D. Thesis, The University of Alabama, Birmingham, U.S.A.
3. Zeren, F. 1982. Freon-12 Vapor Compression Jet Pump Solar Cooling System. Ph.D. Thesis, Texas A&M University, U.S.A.
4. Huang, B. J.; Jiang, C. B.; and Hu, F. L. 1985. Ejector performance characteristics and design analysis of jet refrigeration system. *ASME Trans. J. Eng. for Gas Turbine and Power* 107(July): 792-802.
5. ESDU. 1985. *Ejector and Jet Pump Data Item 86030*. London: ESDU International Ltd.
6. Aphornratana, S. 1996. Theoretical study of a steam-ejector refrigerator. *RE RIC International Energy Journal* 18 (1): 61-74.
7. Keenan, J. H.; Neumann, E. P.; and Lustwerk, F. 1950. An investigation of ejector design by analysis and experiment. *ASME J. Applied Mechanics* (Sept.): 299-309.
8. Munday, J. T., and Bagster, D. F. 1977. A new ejector theory applied to steam jet refrigeration. *Ind. Eng. Chem., Process Des. Div.* 16(4): 442-449.
9. Liepmann, H. W., and Roshko, A. 1957. *Elements of Gas Dynamics*. N.Y.: John Wiley & Sons Inc.
10. Streeter, V. L., and Wylie, E. B. 1975. *Fluid Mechanics*. N.Y.: McGraw-Hill Book Company.