



www.serid.ait.ac.th/eric

Fuzzy-based Load Frequency Controller of a Single Area Power System Considering Governor Nonlinearity

M.F. Hossain*, M. R. Islam*¹, T. Takahashi[†], and M.G. Rabbani*

Abstract – This paper presents the implementation of fuzzy based load frequency controller (FLFC) for controlling the frequency of an automatic generation control (AGC) in electric power generation systems. A typical single area power system is considered with governor dead-band. As a consequence of continually load variation, the frequency of the power system changes over time. In conventional studies, frequency transients are minimized by using conventional proportional integral (PI) controllers aiming of secondary control in AGC and zero steady-state error is obtained after sufficient delay time. In this paper, instead of this method, the configurations of fuzzy load frequency controller (FLFC) is proposed. For any load changes, the proposed controller restores the frequency to its nominal value within the shortest possible time. This controller provides a satisfactory balance between frequency overshoot and transient oscillations with zero steady-state error. All simulation results of the proposed controller are compared with conventional PI controller in both cases with and without governor dead-band.

Keywords – Automatic generation control (AGC), conventional proportional integral (PI) controller, fuzzy load frequency controller (FLFC), governor dead-band (DB), power generation.

1. INTRODUCTION

In electric power generation, system disturbances caused by the load fluctuations which results in changes to the desired frequency value [1]. Load frequency control (LFC), or automatic generation control (AGC) is very important issue in power system operation and control for supplying sufficient and both good quality and reliable electric power [1], [2]. The main goal of the AGC is to maintain zero steady state errors for frequency deviations in single area power system [2]. Most published work on AGC studies adopts a simplified approach [3].

Investigations have shown that following a sudden load change or disturbances in a single area power system, the frequency undergoes a fluctuation which persists for a very long time. This fluctuation is very poorly damped. Since these oscillations are the result of imbalance of power [4], [5]. Automatic Generation Control is adjusted the generation automatically to restore the frequency to the nominal value as the system load changes continuously [6].

The real world power system contains different kinds of uncertainties due to load variations, system modeling errors and change of the power system structure. Since fixed gain controllers are designed for a particular operating point, they may not be suitable for the said AGC problem. Consequently, it is required that a flexible controller be developed. The conventional control strategy for the AGC problem is to take the integral of the control

error as the control signal. An integral controller provides zero steady state deviation, but it exhibits poor dynamic performance [7], especially in the presence of other destabilizing effects such as parameters variations and nonlinearities. To improve the transient response, various control strategies, such as linear feedback, optimal control and variable structure control, have been proposed [8]. However, these methods need some information of the system states, which are very difficult to know completely. There have been continuing efforts in designing AGC with better performance to cope with the plant parameter changes using various adaptive neural networks and robust methods. The proposed methods show good dynamical responses, but their robustness in the presence of model dynamical uncertainties and system nonlinearities was not considered. Also, some of them suggest complex state feedback or high order dynamical controllers, which are not practical for industry practices.

Recently, fuzzy logic has proven to be a prospective tool for dealing with uncertainties in dynamic system. In this direction, Fuzzy Load frequency controller (FLFC) is designed and implemented to improve the transient behavior of the system. Simulation results indicate that the control scheme is able to provide good performance in a single area power system with and without governor dead-band.

2. MODEL OF SINGLE-AREA POWER SYSTEM

In a single power system, load frequency control (LFC) equipment is installed for each generator. The controllers are set for a particular operating condition and take care of small changes in load demand to maintain the frequency within the specified limit. The first step in the analysis and design of a control system is mathematical modeling of the single area power system. Proper assumptions and approximations are made to linearize the mathematical equations describing the system, and a transfer function model is obtained for the component.

* Department of Electrical and Electronic Engineering, Rajshahi University of Engineering and Technology, Rajshahi-6204, Bangladesh.

[†]Department of Electrical and Electronic Engineering, University of Toyama, 3190 Gofuku, Toyama, Japan.

¹ Corresponding author;
Telefax: +88-0721-750356.
E-mail: rabiulbd@hotmail.com.

Figure 1 shows a well-known block diagram used for LFC of a typical single-area power system along with the conventional PI controller only [3], [6], [7].

The dynamic models in state-space variable form of the Figure 1 is:

$$\dot{X} = AX + BU, Y = CX \tag{1}$$

Where,

$X = [\Delta f \ \Delta P_t \ \Delta P_g \ \Delta P_{ref}]^T$; $U = [\Delta P_L]^T$; $Y = [\Delta f]$ are the state vector, the control vector and the output variables respectively.

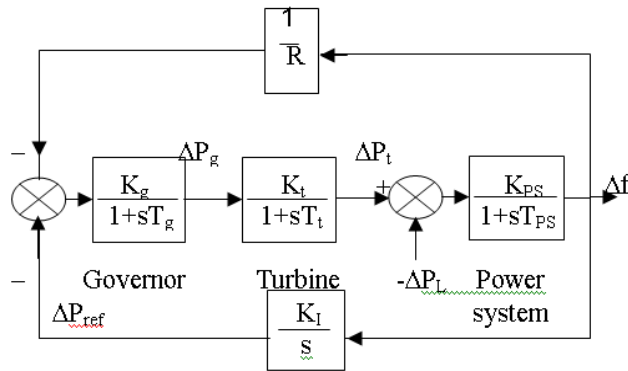

Fig. 1. Transfer function model of LFC for a typical single area power system with PI controller only.

The values of the elements of the system matrices A, B, and C (given below) may be computed from the nominal parameter values [6], [7].

$$A = \begin{bmatrix} -\frac{1}{T_{PS}} & \frac{K_{PS}}{T_{PS}} & 0 & 0 \\ 0 & -\frac{1}{T_t} & \frac{K_g}{T_t} & 0 \\ -\frac{K_g}{RT_g} & 0 & -\frac{1}{T_g} & -\frac{K_g}{T_g} \\ K_I & 0 & 0 & 0 \end{bmatrix}; B = \begin{bmatrix} -\frac{K_{PS}}{T_{PS}} \\ 0 \\ 0 \\ 0 \end{bmatrix}$$

and $C = [1 \ 0 \ 0 \ 0]$;

In this paper, the critical value of integral gain, K_I of conventional PI controller is considered as the base value in the design of the proposed fuzzy logic control scheme.

3. CONSIDERING GOVERNOR DEAD-BAND

Governor dead-band is defined as the total magnitude of a sustained speed change within which there is no resulting change in valve position [10]. The limiting value of dead-band is specified as 0.06%. It was shown by [11], [12], that one of the effects of governor dead-band is to increase the apparent steady-state speed regulation R. This can be seen from Figure 2 by joining points 1 and 2 and multiplying the slope of this line with 1/R. The slope of the line without governor dead-band is 1. Dead-band is measured by plotting automatically from the motion of the governor elements from the frequency.

The speed governor dead-band has significant effect on the dynamic performance of load frequency control system; however, little work has been done in this respect.

In fact this backlash nonlinearity introduces a time lag associated with the zero in the governor transfer function [10].

The governor dead-band of the form shown in Figure 2 exists in real systems and is represented by the nonlinear at points marked DB in Figure 1.

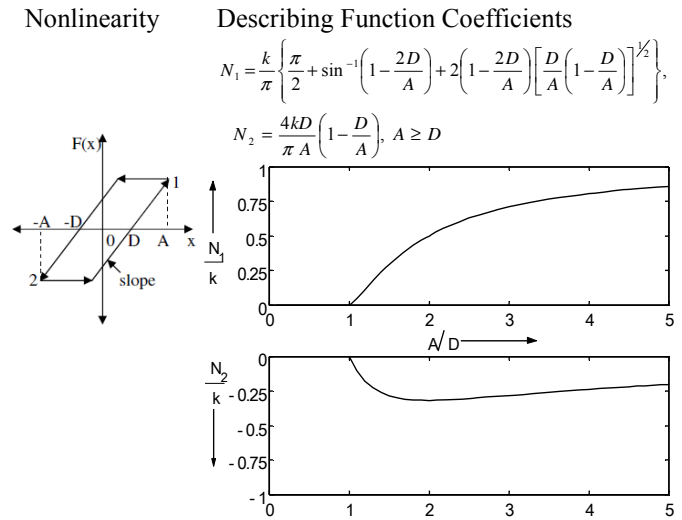

Fig. 2. LHS governor dead-band (backlash) nonlinearity and RHS Fourier series coefficients of governor dead-band.

Referring to Figure 2 it is to be noted that the backlash nonlinearity [10], [13] of the hysteresis type cannot be completely described by the function $F(x)$ since the output inherently depends on the direction of change in x is positive, the right-hand side of the loop represents the nonlinear characteristics and negative for the other side [10]. Thus adequate description of the hysteresis type of nonlinearity is expressed as:

$$y = F(x, \dot{x}) \quad (\text{rather than as } y = F(x)) \tag{2}$$

To solve this nonlinear problem by the describing function approach, [13] has shown that it is necessary to make the basic assumption that the variable x , appearing in the non-linear Function $F(x, \dot{x})$ is sufficiently close to a sinusoidal oscillation; that is:

$$x = A \sin(\omega_0 t) \tag{3}$$

where, the amplitude A and the frequency ω_0 , the oscillation are constant.

If the variable x in the nonlinear assumption $F(x, \dot{x})$ has the sinusoidal form shown in Equation 3, then the variable $F(x, \dot{x})$ is generally complex, but is also a periodic form of time.

$$F(x, \dot{x}) = F^0 + N_1 \dot{x} + \frac{N_2}{\omega_0} \ddot{x} + \dots \tag{4}$$

To solve this it is a reasonable approximation to consider the first three terms only, corresponding coefficients are:

$$\begin{aligned}
 F^0 &= \frac{1}{2\pi} \int_0^{2\pi} F(A \sin w_0 t, A w_0 \cos w_0 t) d(w_0 t) \\
 N_1 &= \frac{1}{\pi A} \int_0^{2\pi} F(A \sin w_0 t, A w_0 \cos w_0 t) \sin w_0 t d(w_0 t) \\
 N_2 &= \frac{1}{\pi A} \int_0^{2\pi} F(A \sin w_0 t, A w_0 \cos w_0 t) \cos w_0 t d(w_0 t)
 \end{aligned}
 \tag{5}$$

Since the backlash nonlinearity is a symmetrical about the origin, the constant term F^0 in the Fourier series (Equation 4) is zero [10]. The constant terms N_1 and N_2 in (Equation 5) are evaluated and displayed in Figure 2 for different values of $A(t)$.

The governor transfer function with linearized dead-band is derived as follows. This will modify the system matrix.

$$G(s) = \frac{N_1 + \frac{N_2}{w_0} s}{1 + T_g s}
 \tag{6}$$

A typical value of backlash is 0.06%. However, by referring to the discussion in references [10], [11], [12], [13], it is found from Figure 2 that $A/D = 4$ will imply a backlash of approximately 0.05%. This value of A/D for backlash of 0.05% is chosen for digital simulation results.

Referring to Figure 2, the following Fourier coefficients are obtained:

$$\frac{N_1}{k} = 0.8 \quad \text{and} \quad \frac{N_2}{k} = -0.2
 \tag{7}$$

The usual value of slope k of the curve shown in Figure 2 is 1. Therefore, $N_1 = 0.08$ and $N_2 = -0.2$.

A typical value of continuous time response, Figure 2, indicates $f_0 = 1/2$ Hz or, $w_0 = 2\pi f_0 = \pi$.

These values of Fourier coefficients are substituted in Equation 4, giving:

$$F(x, \dot{x}) = 0.8x - \frac{0.2}{w}
 \tag{8}$$

4. CRITICAL INTEGRAL GAIN, K_I OF PI CONTROLLER

The tuning of the value of gains K_I at $K_p = 0$ was achieved using a systematic exhaustive search according to the IAET criterion [3] shown in Equation 9.

$$J_{fre} = \int_0^T |\Delta f(t)| t dt
 \tag{9}$$

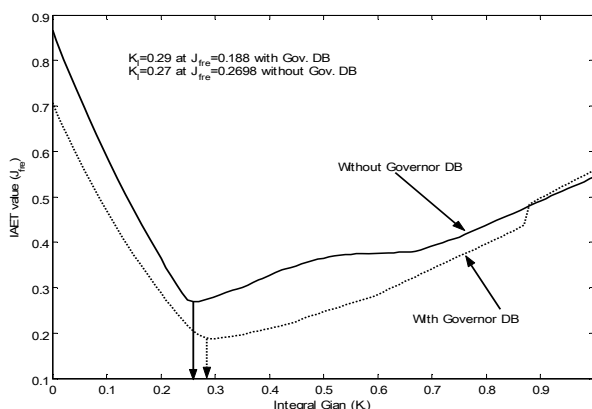

Fig. 3. The optimal K_I setting value for with and without governor dead-band

It is clear from Figure 3 that in the absence of governor dead-band the best tuned of integral gain value is $K_I = 0.29$ at $J_{fre} = 0.188$, which is also called the critical value. In the presence of governor dead-band the integral gain value, $K_I = 0.27$ at $J_{fre} = 0.2698$.

5. FUZZY LOAD FREQUENCY CONTROLLER

In this paper, the fuzzy based load frequency controller (FLFC) is designed, the error (difference about the reference frequency and the sampled frequency) and the rate of change of error will be taken in account. From these variables, it will be deduced the control signal's variation.

The error signal:

$$e^*(k) = r^*(k) - y^*(k)
 \tag{10}$$

and the rate of change of error signal:

$$v^*(k) = \frac{[e^*(k) - e^*(k-1)]}{T_s}
 \tag{11}$$

where, T_s is the sampling period. Figure 4 shows a typical block diagram of FFC controller for an AGC.

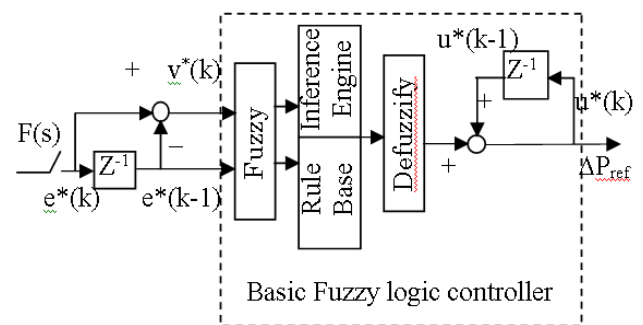

Fig. 4. A typical Fuzzy based load frequency controller (FLFC) for an AGC.

The FLFC works completely by four processes, such as fuzzification, fuzzy rule base, fuzzy inference and defuzzification process. For the FLFC controller the inputs are the frequency variation (i.e. error) and the rate of change in the error defined as:

$$\text{error} = \Delta f = f_{nom} - f_t = e_t
 \tag{12}$$

$$\text{rate of change in error} = \Delta \dot{f} = \dot{f}_{nom} - \dot{f}_t = ce_t$$

The fuzzification procedure consists of finding appropriate membership functions to describe crisp data. In this work, the membership functions have been determined by trial and error method. The precise numerical values are obtained by measurements are converted to membership values of the various linguistic variables [26]. The fuzzy sets of each linguistic variable adopted in this work are: NB: Negative Big; NS: Negative Small; Z: Zero; PS: Positive Small; PB: Positive Big. The membership functions for the designed FLFC controller of the three variables ($e_t, ce_t, \Delta P_{ref}$) used are shown in Figure 5.

It is possible to derive a membership value for this variable in many possible ways, one of the rules that has been chosen is:

$$\mu(e_t, \dot{c} e_t) = \min[\mu(e_t), \mu(\dot{c} e_t)] \tag{13}$$

The fuzzy rules are constructing by using trial and error methods. The output of FLFC controller is given in Table 1.

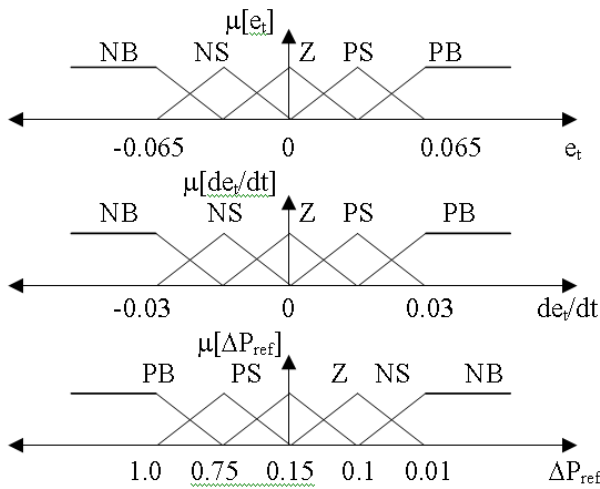

Fig. 5. Membership functions for the fuzzy variables of the proposed FLFC

The well-known center of gravity defuzzification method is given by the following expression:

$$\Delta P_{ref} = \frac{\sum_{j=1}^n \mu_j C_j}{\sum_{j=1}^n \mu_j} \tag{14}$$

where, μ_j is the membership value of the linguistic variable and u_j is the precise numerical value corresponding to that fuzzy controller action. The membership functions, knowledge base and method of defuzzification essentially determine the controller performance.

Table 1. Fuzzy rule base for FLFC controller

$\dot{c} e$	e	NB	NS	Z	PS	PB
NB		PB	PB	PB	PS	Z
NS		PB	PB	PS	Z	NS
Z		NB	Z	NS	NS	NB
PS		Z	Z	NS	NB	NB
PB		Z	NS	NB	NB	NB

6. SIMULATION RESULTS AND DISCUSSIONS

In order to demonstrate the beneficial damping effect of the proposed FLFC controller for an automatic generation controller (AGC) in a single area power system, computer simulations results based on system non-linear differential

equations have been carried out for different load changes. The differential equations have been solved by using the 4th order Range-Kutta method under MATLAB environment. Figures 6 and 7 depict the simulation results with and without considering the governor dead band for step load changes of $\Delta P_L = 0.01$, and 0.02 p.u respectively. The MATLAB software has been used in overall simulation work.

The damping of the system frequency is not found satisfactory with PI controller. With the addition of proposed schemes, the damping is improved significantly. In the absence of governor dead-band, it is evident from the Figure 6 that 1st peak is significantly reduced to 70% of the PI controller performance and the 3rd and 4th peaks of the generator frequency are almost diminished with the proposed mode of control. It is clearly shown that considering governor dead-band, 1st peak is greatly reduced to 45% of the PI controller and also 3rd and 4th peaks are minimized with respect to the PI controller. Moreover, this eventually reduces the settling time of the frequency for both cases, which in turn brings the fuzzy frequency controller in more advantageous position for subsequent use.

Figure 7 shows the system performances with and without governor dead-band. It is clearly observed that in the absence of governor dead-band, the results of 1st, 2nd, 3rd and 4th peaks are same as shown in Figure 6 in comparison with PI controller. In the presence of governor dead-band, 3rd and 4th peaks of the system frequency deviation are almost minimized but PI controller exhibits instability of the system. Therefore, settling time is greatly reduced in the proposed mode of FLFC.

A comparative result for the FLFC and PI controller with and without governor dead-band is given Table 2 and Figure 8. From the comparative results, it is clearly shown the superiority of FLFC controller over the conventional PI controller.

Table 2. Time to reach 1st peak

Step load change	Without governor dead-band		With governor dead-band	
	FLFC	PI	FLFC	PI
0.01	-0.01054	-0.0281	-0.0183	-0.0308
	0.3266s	0.82s	0.576s	0.822s
0.015	-0.01478	-0.0422	-0.0395	-0.054
	0.2761s	0.712s	0.899s	1.13s,
0.02	-0.01922	-0.0562	-0.0686	-0.0857
	0.27s	0.813s	1.077s	1.28s
0.05	-0.046	-0.141	-0.4028	-0.432
	0.252s	0.724s	2.692s	2.77s

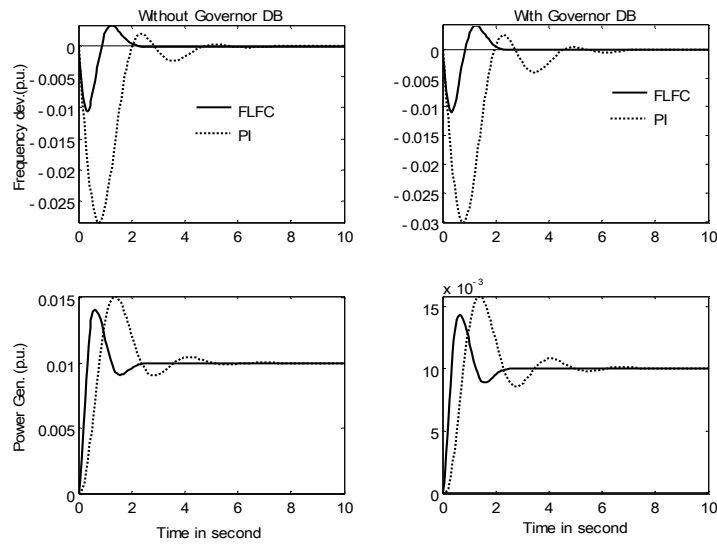

Fig. 6. Frequency deviation, power generation for the step load change $\Delta P_L = 0.01$ p.u. with and without governor dead-band.

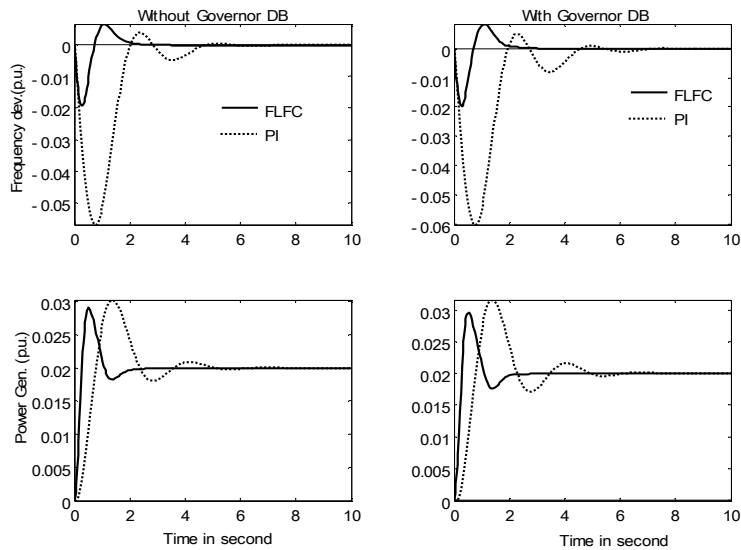

Fig. 7. Frequency deviation, GRC (p.u.) and power generation for the step load change $\Delta P_L = 0.02$ p.u. with and without governor dead-band.

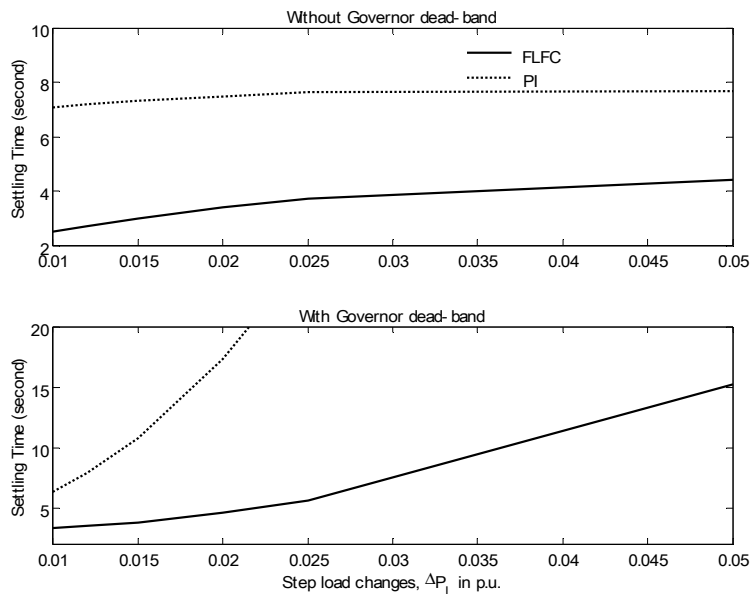

Fig. 8. A comparative settling times of FLFC and PI controller for an AGC in single area power system without and with governor dead-band.

7. CONCLUSION

In this paper, a simple fuzzy based load frequency control (FLFC) for automatic generation control (AGC) is explained. The proposed controller provides a satisfactory stability between frequency overshoot and transient oscillations with zero steady-state error. The various simulation results clearly indicate the superior of the proposed FLFC controller. The 3rd peak is fully diminished by the FLFC scheme. The settling time is reduced to a great extent with the proposed mode of control. The design procedure of the FLFC controller may be applied in multi-area power systems, possibly with simpler structure and with careful examination of its potential properties.

REFERENCES

- [1] Ha, Q.P., and Trinh, H. 2000. A variable structure-based controller with fuzzy tuning for load frequency control. *International Journal of Power and Energy Systems*, 20(3): 146-154.
- [2] Shayeghi, H., Shayanfar, H.A., and Jalili, A. 2006. Multi-stage fuzzy PID power system automatic generation controller in deregulated environments. *Energy Conversion and Management*, 47: 2829-2845.
- [3] Karnavas, Y.L., and Papadopoulos, D.P. 2002. AGC for autonomous power system using combined intelligent techniques. *Electric Power Systems Research*, 62: 225-239.
- [4] Chan, W.C., and Hsu, Y.Y. 1981. Automatic generation control of interconnected power systems using variable-structure controllers. *In IEE Proceedings Pt. C*, 128(5), September.
- [5] Devotta, J.B.X., Rabbani, M.G., and Elagovan, S. 1998. Effects of SMES unit on AGC dynamics. *International Conference on Energy Management and Power Delivery (EMPD'98)*, IEEE Xplore, 1: 61-65, March, Singapore.
- [6] Saadat, H. 2003. *Power System Analysis*. Tata McGraw-Hill Publishing Company Limited, New Delhi.
- [7] Elgerd, O.I. 1983. *Electric Energy Systems Theory*. McGraw-Hill Book Company, New York.
- [8] Liu, F., Song, Y.H., Ma, J., and Lu, Q. 2003. Optimal load frequency control in the restructured power systems. *IEE Proceedings on Generation, Transmission and Distribution*, 150(1): 87-95.
- [9] Kazemi, M.H., Karrari, M., and Menhajm M.B. 2002. Decentralized robust adaptive-output feedback controller for power system load frequency control. *Electrical Engineering*, 84(2): 75-83.
- [10] Tripathy, S.C., Bhatti, T.S., Jha, C.S., Malik, O.P., and Hope, G.S. 1984. Sampled data automatic generation control analysis with reheat steam turbines and governor dead-band effects. *IEEE Transactions on Power Apparatus and System*. PAS-103(4): 1045-1051.
- [11] Concordia, C. Kirchmayer, L.K., and Szmanski, E.A., 1957. Effect of speed governor dead-band on tie-line power and frequency control performance *AIEE Transactions (Power Apparatus and Systems)*, 76: 429-435.
- [12] Kirchmayer, L.K. 1959. *Economic control of interconnected systems*. John Wiley & Sons, New York.
- [13] Silzak, D.D. 1969. *Nonlinear systems: the parameter analysis and design*. John Wiley & Sons, London.